

**Model: HT2615-E**

### Products Overview

---

A new generation HMI, with high reliability, low cost, aluminum-frame, with 3-proofing treatment for the main board, it is suitable for harsh environment. With fully new mould, it uses more practical backward withdraw way, with more beautiful outlook and surface, the HMI is with higher resolution and models.

### Products Overview



---



## Products Specifications

Hardware Parameters	Touch Screen	15.6''16:9 TFT LCD display
	LCD View Angle (T/B/L/R)	85'/85'/85'/85'
	Resolution	1920×1080
	Color	65K
	Brightness	250 cd/m <sup>2</sup>
	Backlight	LED
	LCD Life	50000 hours
	Touch Screen	4-line industrial resistive touch screen
	CPU	1G ARM Cortex-A8
	Memory	256MB FLASH+512MB DDR3
	RTC	Built in
	SD Card	Micro SD (TF) Card
	Ethernet	1-line 10M/100M suitable
	USB Ports	1 USB Slave 2.0 port, 1 USB Host 2.0 port
	Program Downloading	USB Slave/U-disc /Ethernet
	Serial Communication Ports	COM1/ COM3: RS232/RS485/RS422 COM2: RS485/RS422
Electric Specifications	Rated Power	< 18W
	Rated Voltage	DC24V, working range: DC 18V~28V
	Power Protection	It uses power isolated module, with lightning & surging protection.
	Power Down Allowed	< 5mS
	CE & RoHS	Confirms to EN61000-6-2:2005, EN61000-6-4:2007 standard, confirms to RoHS, lightning & surging±1KV, Group Pulse±2KV, Static Contact: 4KV, Air Discharge: 8KV
Environment Specifications	Working Temperature	0~50℃
	Storage Temperature	-20~60℃
	Anti-UV	It prohibits to work under strong UV environment such as direct sunshine.
	Environment Humidity	10~90%RH (Non-condensate)
	Anti-vibration	10~25Hz(X,Y,Z direction 2G/30 minutes)
	Cooling	Natural Cooling
Mechanic Parameters	Installation Way	Embedded Installation/VESA Installation
	Protection Degree	The front panel confirms to IP65(with flat cabinet installation) and the back frame confirms to IP20
	Mechanic Structure	Aluminum frame
	Hole Dimension	380mm×245mm
	Machine Dimension	394mm×256mm×36mm, thickness: 22mm without expanding
	Weight	About 2250g

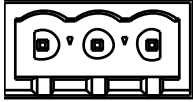
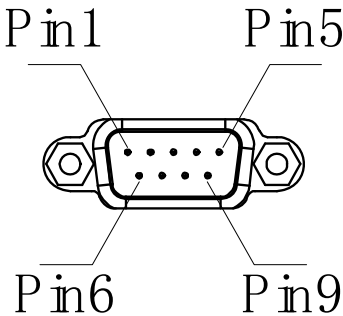
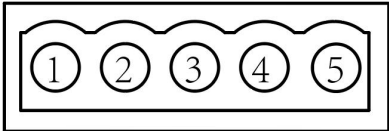
## Wiring Definition

Power Terminals(Pin1~3 from left to right)		
	Pin1	DC24V
	Pin2	GND
	Pin3	FG
DB9 Serial Ports (COM1/COM3)		
	Pin1	Rx-(B)
	Pin2	RxD (COM1 RS232)
	Pin3	TxD (COM1 RS232)
	Pin4	Tx-
	Pin5	GND
	Pin6	Rx+(A)
	Pin7	RxD (COM3 RS232)
	Pin8	TxD (COM3 RS232)
	Pin9	Tx+
COM2 Ports		
	Pin1	Rx+(A)
	Pin2	Rx-(B)
	Pin3	GND
	Pin4	Tx+
	Pin5	Tx-
USB Host		
	USB Type A	Used to connect U-disc, sweep gun etc.
USB Slave		
	Micro USB	Used to download the program and test.

## Dimension

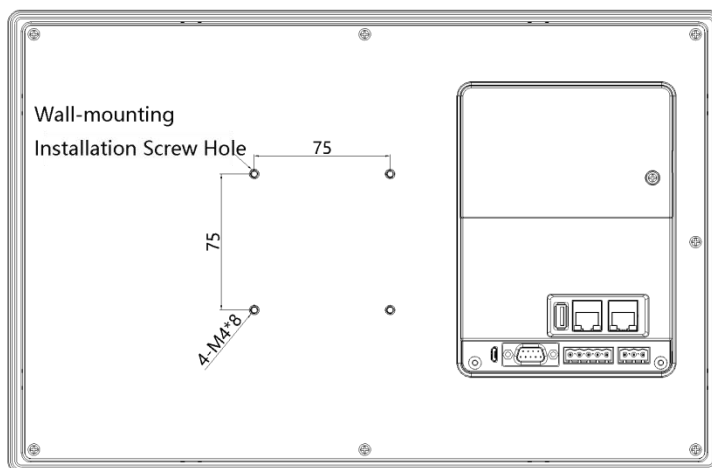
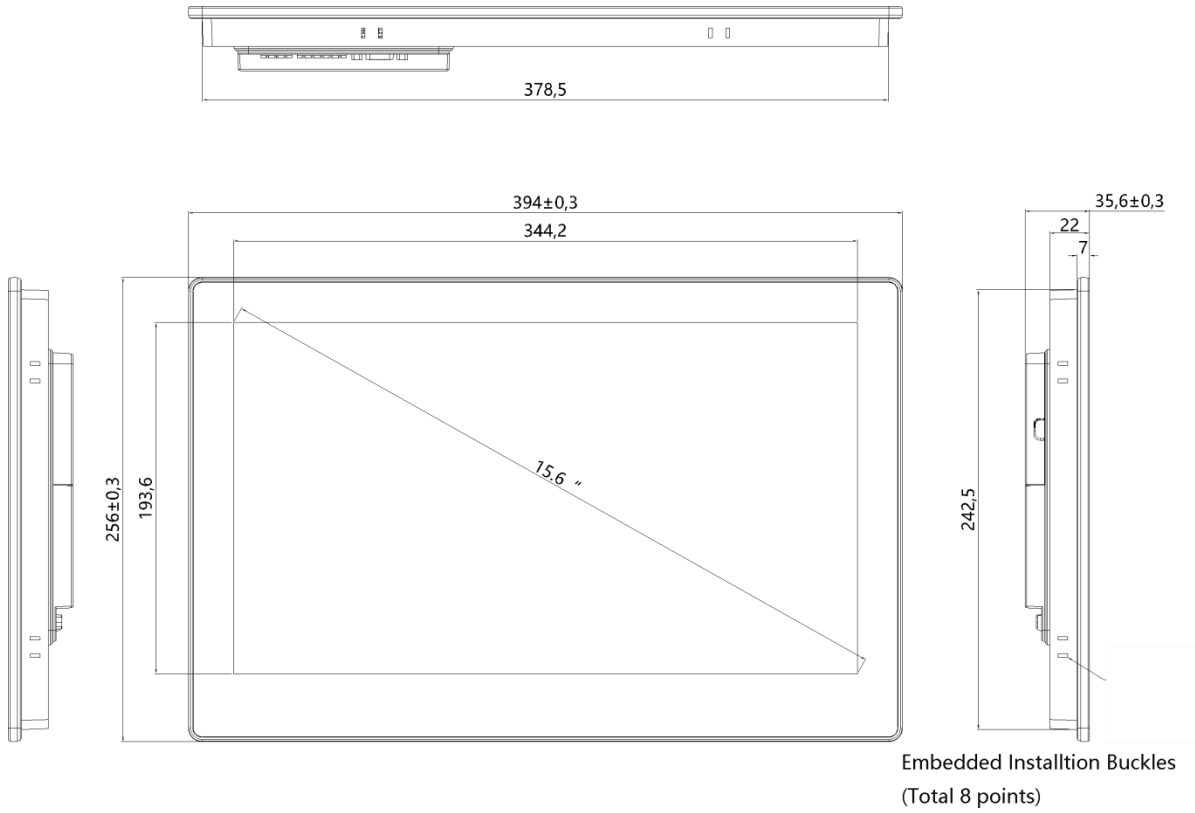

Embedded Installation Hole Dimension : 380mm\*245mm